

PLASTIC CONSTITUTIVE RELATIONS FOR UNIDIRECTIONALLY REINFORCED COMPOSITES: APPLICATION TO LARGE DEFLECTION OF PLATES

M. M. GORJI

Department of Civil Engineering, Shiraz, Iran

(Received in revised form 5 March 1979)

Abstract—The large deflection behavior of the laminated composite plates beyond the elastic limit are investigated. A modified version of Hill's theory for anisotropic metals is used in the analysis of a baron epoxy cross ply symmetric plate under a uniform load and having simply supported immovable edges. An alternate set of plastic stress-strain relations is also employed wherein the effects of hydrostatic pressure on yielding and compressibility in the plastic range of composite materials in the initial stage of plastic deformation are considered. The solutions of both approaches are thus compared.

INTRODUCTION

One commonly used composite structure consists of many layers or laminae bonded one on top of another to form a high strength laminated composite. Each of the lamina may be considered as anisotropic, homogenous material.

The incorporation of high strength and high modulus filaments in a low strength and low modulus matrix material can result in a structural composite material with high strength to weight ratio. Thus, the potential of two-material composite for use in aircraft, space vehicle, and propulsion system has stimulated considerable research activities in the theoretical prediction of the behavior of anisotropic laminated media.

The classical laminated plate theory based on Kirchhoff assumptions has been well established[1-3]. Various investigations of the elastic large deflection behavior of orthotropic plates have been undertaken by different researchers[4-13]. However, most of the currently used matrix materials in composites have high strain capabilities. In the investigation of the bending of composite plates undergoing large deformation yielding is apt to occur and its effect must be accounted for in the analysis.

Various studies on the plastic behavior of anisotropic materials have been undertaken by different researchers[14-28]. Utilizing a finite element formulation, Lin *et al.*[29] suggested an important difference between the inelastic behavior of composite materials and homogeneous metals, namely the existence of yielding under hydrostatic pressure. Consequently, the analytical formulation of macroscopic yield condition and flow rules will have to account for this effect. It also follows that during plastic flow of the matrix, composite will exhibit volume change in plastic flow due to the elastic compressibility of the matrix and fibers. Therefore, numerous restrictive assumptions made in the development of the plastic behavior of composite materials do not represent the real material.

In view of the above discussions, it is noted that a realistic macroscopic yield condition and flow rule to be used in the analysis of composite materials subjected to the biaxial state of stress, such as plate bending problems, is lacking at this time. However, an approximate theory may be constructed by utilizing the initial yield surfaces given by Lin *et al.*[30].

The purpose of this investigation is to study the large deflection behavior of the laminated composite plates beyond the elastic limit. The incremental plasticity theories employed in the analysis are:

- (1) A modification to Hill's Theory[16] has been made[31, 32] by treating the anisotropic parameters as variables whose values are dependent on the current level of stresses. Hence, the restriction on the proportional increase in yield stresses is removed and thus the subsequent surfaces do not retain the same initial shape.
- (2) An appropriate set of plastic constitutive relations for composite materials in the initial stage of plastic deformation is developed wherein the effects of hydrostatic pressure on yielding and compressibility in the plastic range are considered.

The modified Hill's Theory and the alternate approach are used in the analysis of a boron epoxy symmetric cross ply laminated plate under a uniformly distributed loading. The edges are assumed to be immovable in the plane of the plate and simply supported. The equivalent load concept [33] in which the inelastic strain components as well as the nonlinear terms of displacements are considered as an additional set of lateral loads is utilized in obtaining the solution to the example problem.

MATHEMATICAL FORMULATION

A multilayer composite consists of a number of unidirectional layers with different fiber orientations. Consider a plate composed of n laminae as shown in Fig. 1. Let x , y and z be a set of coordinates with x and y axis located in the middle plane of the plate and z -axis pointing downward. The components of displacement of the middle surface along x , y , and z axis are denoted by U , V , and W , respectively. A typical lamina (i) is bounded by planes $z = h_i$ at the bottom and $z = h_{i-1}$ at the top of the lamina. From Kirchhoff's assumption of plates, the well known strain displacement relations, the constitutive relations for the K th orthotropic layer in a state of plane stress, the forces and moments are given as [1]

$$\begin{aligned}\epsilon_x &= U_{,x} + 1/2 W_{,x}^2 - ZW_{,xx} \\ \epsilon_y &= V_{,y} + 1/2 W_{,y}^2 - ZW_{,yy}\end{aligned}\quad (1)$$

$$2\epsilon_{xy} = U_{,y} + V_{,x} + W_{,x}W_{,y} - 2ZW_{,xy}$$

$$\begin{matrix} (K) \\ \left\{ \begin{matrix} \sigma_x \\ \sigma_y \\ \tau_{xy} \end{matrix} \right\} \end{matrix} = \begin{matrix} (K) \\ \left[\begin{matrix} Q_{11} & Q_{12} & Q_{16} \\ Q_{12} & Q_{22} & Q_{26} \\ Q_{16} & Q_{26} & Q_{66} \end{matrix} \right] \end{matrix} \begin{matrix} \left\{ \begin{matrix} \epsilon_x - \epsilon'_x \\ \epsilon_y - \epsilon'_y \\ 2(\epsilon_{xy} - \epsilon'_{xy}) \end{matrix} \right\} \end{matrix}\quad (2)$$

$$\begin{aligned}\left\{ \begin{matrix} N_x \\ N_y \\ N_{xy} \end{matrix} \right\} &= \left[\begin{matrix} A_{11} & A_{12} & A_{16} \\ A_{12} & A_{22} & A_{26} \\ A_{16} & A_{26} & A_{66} \end{matrix} \right] \left\{ \begin{matrix} \epsilon_x - ZW_{,xx} \\ \epsilon_y - ZW_{,yy} \\ 2(\epsilon_{xy} - ZW_{,xy}) \end{matrix} \right\} \\ &- \left[\begin{matrix} B_{11} & B_{12} & B_{16} \\ B_{12} & B_{22} & B_{26} \\ B_{16} & B_{26} & B_{66} \end{matrix} \right] \left\{ \begin{matrix} W_{,xx} \\ W_{,yy} \\ 2W_{,xy} \end{matrix} \right\} - \left\{ \begin{matrix} N'_x \\ N'_y \\ N'_{xy} \end{matrix} \right\}\end{aligned}\quad (3)$$

$$\begin{aligned}\left\{ \begin{matrix} M_x \\ M_y \\ M_{xy} \end{matrix} \right\} &= \left[\begin{matrix} B_{11} & B_{12} & B_{16} \\ B_{12} & B_{22} & B_{26} \\ B_{16} & B_{26} & B_{66} \end{matrix} \right] \left\{ \begin{matrix} \epsilon_x - ZW_{,xx} \\ \epsilon_y - ZW_{,yy} \\ 2(\epsilon_{xy} - ZW_{,xy}) \end{matrix} \right\} \\ &- \left[\begin{matrix} D_{11} & D_{12} & D_{16} \\ D_{12} & D_{22} & D_{26} \\ D_{16} & D_{26} & D_{66} \end{matrix} \right] \left\{ \begin{matrix} W_{,xx} \\ W_{,yy} \\ 2W_{,xy} \end{matrix} \right\} - \left\{ \begin{matrix} M'_x \\ M'_y \\ M'_{xy} \end{matrix} \right\}.\end{aligned}\quad (4)$$

Where ϵ'_{ij} and Q_{ij} denote the components of plastic strain and the reduced stiffness coefficients, respectively, and

$$(A_{ij}, B_{ij}, D_{ij}) = \int_{-h/2}^{h/2} Q_{ij}(1, Z, Z^2) dZ \quad (5)$$

$$(N'_i, M'_i) = \int_{-h/2}^{h/2} Q_{ij}\epsilon'_j(1, Z) dz. \quad (6)$$

Note that the contracted notation is used in eqn (6). Repeated index implies summation over the range of that index.

Consider a symmetrical cross ply laminated plate composed of laminae oriented such that their principal material directions correspond to the coordinate axes. Using the above relations, with no applied body forces, the equation of equilibrium can be expressed in terms of the

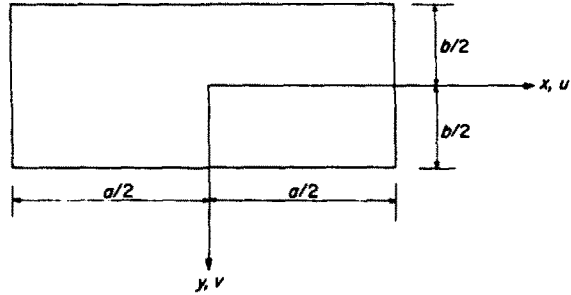
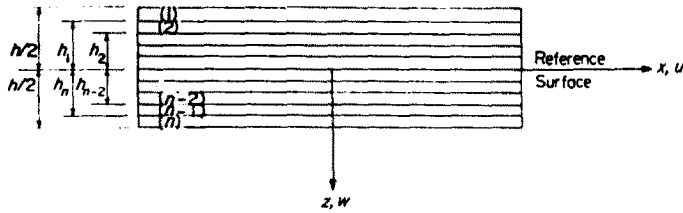

Fig. 1. Plate notation.

middle surface displacements as

$$A_{11}U_{,xx} + A_{66}U_{,yy} + (A_{12} + A_{66})V_{,xy} + \bar{X} + X'' = 0 \tag{7a}$$

$$A_{66}V_{,xx} + A_{22}V_{,yy} + (A_{12} + A_{66})U_{,xy} + \bar{Y} + Y'' = 0 \tag{7b}$$

$$D_{11}W_{,xxxx} + 2(D_{12} + D_{66})W_{,xxyy} + D_{22}W_{,yyyy} = q + \bar{q} + q'' \tag{7c}$$

where

$$\begin{aligned} \bar{X} &= W_{,x}(A_{11}W_{,xx} + A_{66}W_{,yy}) + (A_{12} + A_{66})W_{,y}W_{,xy} \\ \bar{Y} &= W_{,y}(A_{66}W_{,xx} + A_{22}W_{,yy}) + (A_{12} + A_{66})W_{,x}W_{,xy} \\ \bar{q} &= N_xW_{,xx} + N_yW_{,yy} + 2N_{xy}W_{,xy} \end{aligned} \tag{8}$$

and

$$\begin{aligned} X'' &= -\left[\frac{\partial}{\partial x} \int_{-N/2}^{N/2} Q_{1j}\epsilon_j'' dZ + \frac{\partial}{\partial y} \int_{-N/2}^{N/2} Q_{66}\epsilon_6'' dZ \right] \\ Y'' &= -\left[\frac{\partial}{\partial y} \int_{-N/2}^{N/2} Q_{2j}\epsilon_j'' dZ + \frac{\partial}{\partial x} \int_{-N/2}^{N/2} Q_{66}\epsilon_6'' dZ \right] \\ q'' &= -\left[\frac{\partial^2}{\partial x^2} \int_{-N/2}^{N/2} Q_{1j}\epsilon_j'' Z dZ + \frac{2\partial^2}{\partial x \partial y} \int_{-N/2}^{N/2} Q_{66}\epsilon_6'' Z dZ + \frac{\partial^2}{\partial y^2} \int_{-N/2}^{N/2} Q_{2j}\epsilon_j'' Z dZ \right]. \end{aligned} \tag{9}$$

INCREMENTAL PLASTIC STRESS-STRAIN RELATIONS

Let \$X_i (i = 1, 2, 3)\$ be a set of rectangular coordinate system with \$X_1, X_2\$ in the plane of the lamina and \$X_3\$ oriented along the filament direction. A modification of the plasticity theory for anisotropic metals proposed by Hill [16] has been made by Hu [31] and Jensen *et al.* [32]. For a

detail presentation of the modified Hill's theory (MHT) the reader may consult the above mentioned references. The stress-plastic strain increment relations for (MHT) are given here, for convenience, by

$$\begin{aligned}\Delta\epsilon''_1 &= (\alpha_{11}\sigma_{11} - \alpha_{12}\sigma_{22} - \alpha_{13}\sigma_{33}) \frac{\Delta\epsilon''^*}{\sigma^*} \\ \Delta\epsilon''_2 &= (-\alpha_{12}\sigma_{11} + \alpha_{22}\sigma_{22} - \alpha_{23}\sigma_{33}) \frac{\Delta\epsilon''^*}{\sigma^*} \\ \Delta\epsilon''_3 &= (-\alpha_{13}\sigma_{11} - \alpha_{23}\sigma_{22} + \alpha_{33}\sigma_{33}) \frac{\Delta\epsilon''^*}{\sigma^*} \\ \Delta\epsilon''_{12} &= \frac{3}{2} \alpha_{44} \tau_{12} \frac{\Delta\epsilon''^*}{\sigma^*} \\ \Delta\epsilon''_{23} &= \frac{3}{2} \alpha_{55} \tau_{23} \frac{\Delta\epsilon''^*}{\sigma^*} \\ \Delta\epsilon''_{13} &= \frac{3}{2} \alpha_{66} \tau_{13} \frac{\Delta\epsilon''^*}{\sigma^*}\end{aligned}\quad (10)$$

where σ^* , $\Delta\epsilon''^*$, α_{ij} are the effective stress, effective plastic strain increment, and anisotropic parameters, respectively. The generalization of the uniaxial stress-strain curve in 2-2 direction leads to

$$\alpha_{22} = 1.0 \quad (11)$$

$$\epsilon''^* = g(\sigma^*).$$

The relation for the effective plastic strain increment for the state of plane stress ($\sigma_{33} = \tau_{13} = \tau_{23} = 0$) is given as

$$\Delta\epsilon''^* = \frac{g'(\sigma^*)}{\sigma^*} [(\alpha_{11}\sigma_{11} - \alpha_{12}\sigma_{22})\Delta\sigma_{11} + (\sigma_{22} - \alpha_{12}\sigma_{11})\Delta\sigma_{22} + 3\alpha_{44}\tau_{12}\Delta\tau_{12}]. \quad (12)$$

Equations (10) and (12) are combined to obtain the incremental stress-strain relations.

An alternate set of plastic stress-strain relations (AT) is developed herein where the effects of hydrostatic pressure on yielding and compressibility in the plastic range of composite materials are considered. Using the reciprocal theorem for displacements in the inelastic bodies of both homogeneous and composite materials, Lin has shown that yield surfaces coincide with plastic potential[34]. The existence of the initial yield surface[30] thus offers a means of calculating the incremental plastic strain vector for the initial stage of plastic deformation.

An analytical expression for yielding function was obtained by fitting curves to the initial yield loci. Thus the yielding surface in σ_{11} , σ_{22} , τ_{12} space may be represented by

$$f(\sigma_{ij}) = \left(\frac{\sigma_{11}}{\phi_{11}}\right)^2 + \left(\frac{\sigma_{22}}{\phi_{22}}\right)^2 - \frac{\sigma_{11}\sigma_{22}}{\phi_{33}} + \left(\frac{\tau_{12}}{\phi_{55}}\right)^2 = 1 \quad (13)$$

where ϕ 's are known constants. Since the yielding function has approximately the same representation in two transverse directions X_2 and X_3 , eqn (13) may be generalized to the case of a three dimensional body as

$$f(\sigma_{ij}) = \left(\frac{\sigma_{11}}{\phi_{11}}\right)^2 + \left(\frac{\sigma_{22}}{\phi_{22}}\right)^2 + \left(\frac{\sigma_{33}}{\phi_{22}}\right)^2 - \frac{\sigma_{11}\sigma_{33}}{\phi_{33}} - \frac{\sigma_{22}\sigma_{33}}{\phi_{44}} + \left(\frac{\tau_{12}}{\phi_{55}}\right)^2 + \left(\frac{\tau_{13}}{\phi_{55}}\right)^2 + \left(\frac{\tau_{23}}{\phi_{66}}\right)^2 = 1. \quad (14)$$

Note that due to this generalization of the yielding function two additional constants ϕ_{44} and ϕ_{66} are introduced whose values are yet to be determined.

The procedure used to derive plastic stress-strain relations for composite materials is similar to that employed for the case of an isotropic medium [35]. A loading function of the form given by relation (14) is assumed for the initial stage of plastic deformation. Since the yield surface of a composite material is shown to coincide with plastic potential, the plastic stress-strain increment vector may be taken along the gradient of the yielding function. Accordingly

$$d\epsilon''_{ij} = n_{ij} n_{kl} ds_{kl} \quad k, l = 1, 2, 3 \quad (15)$$

$$n_{ij} = \frac{\partial f}{\partial \sigma_{ij}} \frac{1}{|\nabla f|} \quad (16)$$

n_{ij} 's are the direction cosines of a unit normal to the yielding function. The term ds_{kl} is defined as

$$ds_{kl} = \beta_{kl} d\sigma_{kl} \quad (17)$$

where no sum on indices k and l is implied in eqn (17). β_{kl} 's are the constants of proportionality to be evaluated from uniaxial test data. Since the initial stage of plastic deformation is considered in this investigation, the magnitudes of β_{kl} are evaluated at the initial yield and are assumed to remain constant. Using eqn (14), relation (16) may be expressed in terms of σ_{ij} , ϕ 's, and $|\nabla f|$. When carrying out the partial differentiation in eqn (16), σ_{ij} and σ_{kl} ($i \neq j$) are considered to be different terms. The resulting relations may now be used together with eqns (15), (17) and the uniaxial test data to obtain the constants of proportionality β_{kl} . Thus,

$$\begin{aligned} \beta_{11} &= \left(1 + \frac{\phi_{11}^4}{2\phi_{33}^2}\right) \frac{1}{E''_{11}} \\ \beta_{22} &= \left(1 + \frac{\phi_{22}^4}{4\phi_{33}^2} + \frac{\phi_{22}^4}{4\phi_{44}^2}\right) \frac{1}{E''_{22}} \\ \beta_{33} &= \beta_{22} \\ \beta_{12} &= \beta_{21} = \frac{1}{2G''_{12}} \\ \beta_{13} &= \beta_{31} = \frac{1}{2G''_{13}} \\ \beta_{23} &= \beta_{32} = \frac{1}{2G''_{23}} \end{aligned} \quad (18)$$

where E'' 's and G'' 's are the plastic moduli and plastic shear moduli, respectively. Equations (15)–(18) may be combined to obtain the constitutive relations for a plastically deformed composite material. The relations obtained thus far may be specialized to a plane stress case. We then have

$$\begin{aligned} n_{11} &= \frac{1}{|\nabla f|} \left(\frac{2\sigma_{11}}{\phi_{11}^2} - \frac{\sigma_{22}}{\phi_{33}} \right) \\ n_{22} &= \frac{1}{|\nabla f|} \left(\frac{2\sigma_{22}}{\phi_{22}^2} - \frac{\sigma_{11}}{\phi_{33}} \right) \\ n_{33} &= \frac{-1}{|\nabla f|} \left(\frac{\sigma_{11}}{\phi_{33}} + \frac{\sigma_{22}}{\phi_{44}} \right) \\ n_{12} &= n_{21} = \frac{1}{|\nabla f|} \frac{\tau_{12}}{\phi_{55}^2} \end{aligned} \quad (19)$$

where

$$|\nabla f| = \left[\left(\frac{2\sigma_{11}}{\phi_{11}^2} - \frac{\sigma_{22}}{\phi_{33}} \right)^2 + \left(\frac{2\sigma_{22}}{\phi_{22}^2} - \frac{\sigma_{11}}{\phi_{33}} \right)^2 + \left(\frac{\sigma_{11}}{\phi_{33}} + \frac{\sigma_{22}}{\phi_{44}} \right)^2 + 2 \frac{\tau_{12}^2}{\phi_{33}^4} \right]^{1/2} \quad (20)$$

and

$$\Delta \epsilon''_{ij} = n_{ij} \left[\frac{n_{11}}{E''_{11}} \left(1 + \frac{\phi_{11}^4}{2\phi_{33}^2} \right) \Delta \sigma_{11} + \frac{n_{22}}{E''_{22}} \left(1 + \frac{\phi_{22}^4}{4\phi_{33}^2} + \frac{\phi_{22}^4}{4\phi_{44}^2} \right) \Delta \sigma_{22} + \frac{n_{12}}{G''_{12}} \Delta \tau_{12} \right]. \quad (21)$$

Examination of eqns (19)–(21) reveals the presence of ϕ_{44} in these equations. It was mentioned earlier that due to the generalization of the result of the theoretical initial yield surface to a three dimensional case two additional constants, namely ϕ_{44} and ϕ_{66} , were introduced into the expression for yielding function. The generalization of yielding function is necessary in order to obtain correct plastic constitutive relations. This is evident by the presence of additional terms in the two dimensional case given by eqns (19)–(21). Utilizing the data of Ref. [36], the initial yield surface in σ_{22} , σ_{33} , τ_{23} space was constructed for the example problems. The magnitude of ϕ_{44} was thus determined.

METHOD OF SOLUTION

It has been shown that the inelastic strains and the nonlinear terms due to lateral deflection can be considered as a combination of equivalent lateral loads, edge moments, and in-plane forces [33]. Thus, the solution of an inelastic Von Karman type plate can be reduced to that of an equivalent elastic plate with small displacements. In this paper the governing equations of symmetric cross-ply laminated plates given by eqns (7)–(9) will be considered. However, the method of solution is general and may be used to solve the governing equations in the most general form.

The incremental constitutive relations, eqns (10) and (12) or (21), are employed in this analysis. The displacement, stress, and strain fields are obtained by the solution of eqns (7) together with relations (8) and (9) in their incremental form. An iteration procedure used to solve these equations is described below:

Consider a plate with arbitrary boundary conditions under the action of a lateral load of intensity q . Let this load be increased by increments Δq until the desired load is reached. The increments of lateral displacement, plastic strain, etc. are denoted by double subscripted notations, where the first subscript is associated with load increment and the second subscript denotes the cycle of iteration. Thus, $\Delta W_{(n+1)m}$ and $\Delta \epsilon''_{(n+1)m}$ refer, respectively, to the increments of lateral displacement and plastic strain due to the $(n+1)^{\text{th}}$ load increment at the end of m^{th} cycle. When the final values of these variables are reached, the second subscript is deleted.

For the $(n+1)^{\text{th}}$ incremental applied load, assume that the resulting incremental lateral displacement and plastic strain are equal to those obtained at the end of the n^{th} load increment. This indicates that

$$\Delta W_{(n+1)1} = \Delta W_n$$

$$\Delta \epsilon''_{ij(n+1)1} = \Delta \epsilon''_{ij_n}$$

$$W_{(n+1)1} = W_n + \Delta W_{(n+1)1}.$$

Using these relations in eqns (8) and (9), the trial values of the equivalent body forces $\Delta \bar{X}_{(n+1)1}$, $\Delta \bar{Y}_{(n+1)1}$, $\Delta X'_{(n+1)1}$, $\Delta Y'_{(n+1)1}$, and lateral load $\Delta q'_{(n+1)1}$ are obtained. It must also be noted that the magnitude of $\Delta \bar{q}_{(n+1)1}$ is not known at this time. With the trial values of $\Delta \bar{X}$, $\Delta \bar{Y}$, $\Delta X''$, and $\Delta Y''$ known, eqns (7a,b) are solved to determine the incremental in-plane displacements $\Delta U_{(n+1)1}$ and $\Delta V_{(n+1)1}$. This is a plane stress problem with given boundary conditions and applied forces. The numerical method of finite difference or finite element can be employed to evaluate $\Delta U_{(n+1)1}$ and $\Delta V_{(n+1)1}$. Thus, the membrane forces $\Delta N_{x(n+1)1}$, $\Delta N_{y(n+1)1}$, $\Delta N_{xy(n+1)1}$ and consequently $N_{x(n+1)1}$, $N_{y(n+1)1}$ and $N_{xy(n+1)1}$ may be evaluated. Having obtained the in-plane forces, the terms

$\Delta \bar{q}_{(n+1)1}$ and $\bar{q}_{(n+1)1}$ can be determined. Using the trial values of lateral displacement, plastic strain, and in-plane displacements in eqn (2), stresses $\Delta \tau_{ij(n+1)}$ and hence $\tau_{ij(n+1)}$ are determined. The plastic constitutive relations given by eqns (10) and (12) or (21) are consequently utilized to evaluate the incremental components of plastic strain. Denote these components by $\Delta \epsilon''_{ij(n+1)2}$. Inserting values of $\Delta \bar{q}_{(n+1)1}$, $\Delta \bar{q}''_{(n+1)1}$, and the applied load increment Δq into eqn (7c) allows for the determination of lateral displacement $\Delta w_{(n+1)2}$. With the new values of $\Delta W_{(n+1)2}$ and $\Delta \epsilon''_{ij(n+1)2}$ known, the same procedure is repeated until the difference between the successive values of ΔW and $\Delta \epsilon''_{ij}$ are within desired limits. Thus the lateral displacements, stresses and strains in a plate due to bending under both large deflection and plastic strain are obtained.

NUMERICAL EXAMPLES

Consider a simply supported symmetrical laminated plate composed of four layers of fiber reinforced laminae of equal thickness. Each lamina consists of Narmco epoxy matrix reinforced by boron fibers along a single direction and having $10'' \times 10'' \times 3/32''$ dimensions. The plate is subjected to a uniformly distributed lateral load and the edges are assumed to be immovable in the plane of plate. The boundary conditions are thus given as

$$W = M_x = U = V = 0 \quad \text{at } x = \pm \frac{a}{2}$$

$$W = M_y = U = V = 0 \quad \text{at } y = \pm \frac{a}{2}.$$

For simply supported edges, the only non-zero moment along the boundaries of an elastic rectangular plate is M_{xy} . Hence only M''_{xy} will develop while M'_x and M'_y remain zero on the boundaries when the plastic range is propagated to edges. Thus, the presence of plastic strain will not violate the boundary conditions and no modification of the boundary conditions is necessary for the equivalent plate when the plate is rectangular [33].

The uniaxial relation in transverse direction is approximated by the following relations

$$\epsilon = \frac{\sigma}{E} \left[\frac{\sigma - (\sigma_y)_T}{\sigma_0} \right]^n$$

and

$$d\epsilon'' = n \left[\frac{\sigma - (\sigma_y)_T}{\sigma_0} \right]^{n-1} \frac{d\sigma}{\sigma_0} \quad \text{when } \sigma \geq (\sigma_y)_T$$

$$d\epsilon'' = 0 \quad \text{when } \sigma < (\sigma_y)_T.$$

Where $(\sigma_y)_T$ denotes tensile yield stress in transverse direction. The magnitudes of constants n and σ_0 together with material properties are listed in Table 1. The initial yield surface for longitudinal normal σ_{11} , transverse normal σ_{22} , and longitudinal shear τ_{12} loading for boron composite material [36] is given in Fig. 2.

While the elastic solutions for plate bending problems under arbitrary loadings are generally known [37], the analytical solutions for plane stress problems of finite region under body forces are not often available. However, with the use of numerical techniques such as finite element method [38] the solution of an elastic plane stress problem is possible.

The plane of plate is divided into 10×10 square grids while the thickness of each layer is divided into three equal increments. For the plane stress problem, each square grid consists of four constant strain triangular elements. Such a quadrilateral involves fewer number of unknowns than four triangles. In addition, it ensures that the solution is independent of the skew of subdivision mesh. The influence coefficients of stress N_x , N_y , N_{xy} may therefore be obtained. Using the known linear elastic solution for the plate bending, influence coefficients of lateral displacements were also determined.

Table 1.

Boron Epoxy†	
†Modulus of elasticity, psi	$E_L = 31.9 \times 10^6$ $E_T = 3.1 \times 10^6$
Shear modulus, psi	$G_{L,T} = 1 \times 10^6$
Poisson's ratio	$\nu_{L,T} = 0.208$
Plastic modulus, psi	$E_p^L = 3.5 \times 10^5$ $E_p^T = 5.22 \times 10^5$
Plastic shear modulus, psi	$G_{L,T} = 1.136 \times 10^5$
Yield stresses, psi (from the unidirectional test data)	$(\sigma_y)_L = 1.6 \times 10^5$ $(\sigma_y)_T = 8 \times 10^3$ $(\tau_y)_{L,T} = 3 \times 10^3$
σ_0 psi	7.8×10^3
n	1.33

†The subscripts L and T refer to directions parallel and transverse to fibers, respectively.

‡Ref. [41].

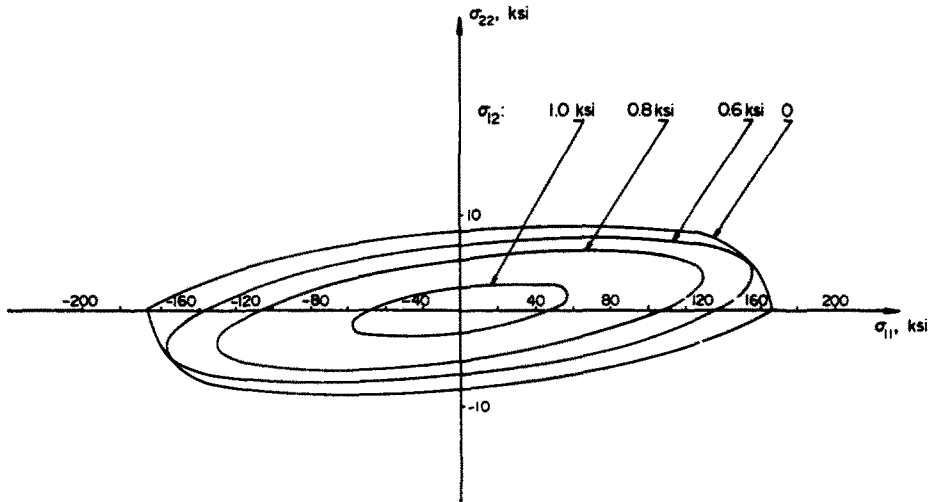

Fig. 2. Initial yield loci for Boron-Narmco epoxy composite, $V_f = 0.5$.

The (MHT) is used to obtain an elastic-plastic solution. In addition, the consideration of the effects of hydrostatic pressure on yielding and compressibility in the plastic range offered by (AT) is also employed in the analysis of composite plates.

The results of the elastic-plastic plate for both (MHT) and (AT) at $q = 400$ psi are shown in Figs. 3-6. The linear and nonlinear elastic solutions are also included for the purpose of comparison. The results of center displacement shown in Fig. 3 indicate that the elastic-plastic case yields higher values than the elastic ones. However, the (MHT) results in slightly higher displacements. The variation of the extreme fiber stresses at the center of plate are given in Figs. 4 and 5 while the value of shear stress at the corner of the plate is shown in Fig. 6. Although the difference in the magnitude of σ_x for elastic and elastic-plastic solutions is slight, the deviation of σ_y component of stress is more pronounced. This may be attributed to the fact that, in the lamina considered, fibers are oriented in X direction, i.e. absence of any pronounced inelasticity in the fiber direction. It must be noted that the extreme fiber shear stress at the corner of the plate is considerably relieved by plastic strain. The progress of plastic zone for (MHT) is somewhat different than (AT) for the example problem considered. The center of the plate yields initially when the plastic constitutive relations of (MHT) are used. Consequently as

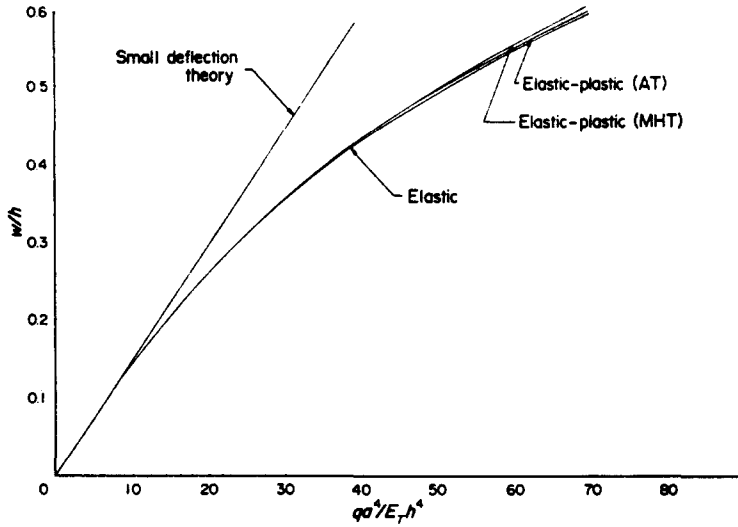

Fig. 3. Deflection at the center of the plate, boron epoxy.

the load is increased, plastic range is propagated from center toward edges. However, before the plastic deformation completely reaches the edges, the corner of the plate starts yielding and the plastic deformation in turn propagates toward the center of the plate. Employing (AT) in the elastic-plastic analysis, plastic strain is first initiated at the corner of the plate and the central point starts yielding at a higher load. The following argument can be used to explain the difference in the progress of the plastic zones resulting from two approaches: Recall that in (MHT) yielding stresses are determined from each of the directional stress-strain test data while the result of the theoretical initial yield surface is used in (AT) to predict these yield stresses. The origin of the coordinate axes in the stress space, shown in Fig. 2, corresponds to the stress at a point in matrix which has reached the elastic limit under a state of pure shear. The magnitude of the yield stress in pure shear for boron epoxy composite of Fig. 2 is found to be 1.05 ksi as opposed to a value of 3 ksi found from shearing stress-strain curve. This discrepancy

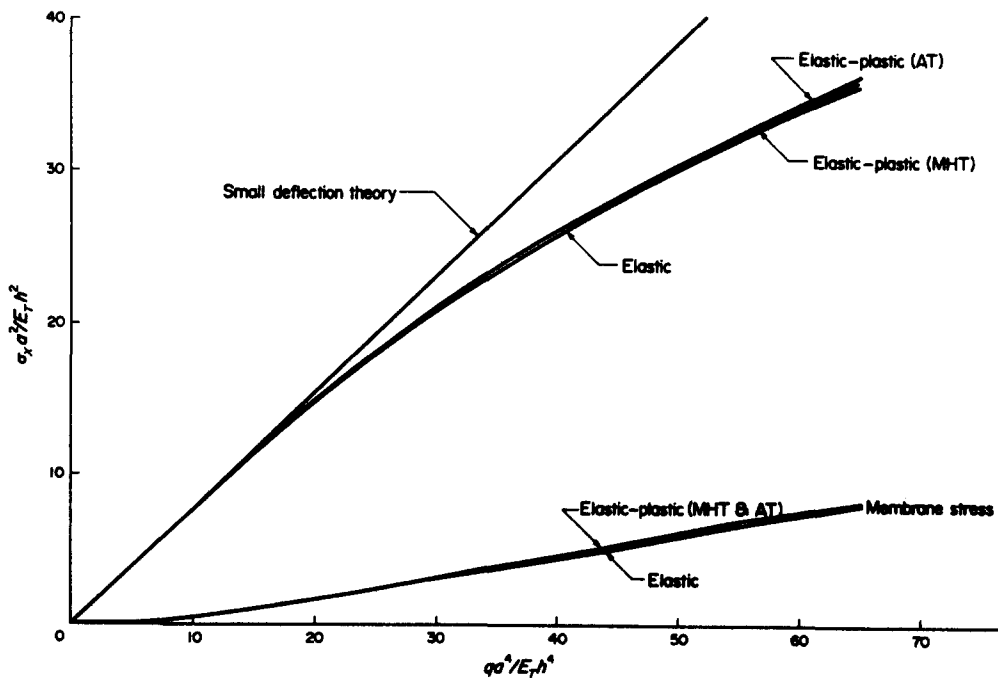

Fig. 4. Variation of the extreme fiber stress σ_x with load at the center of the plate, boron epoxy.

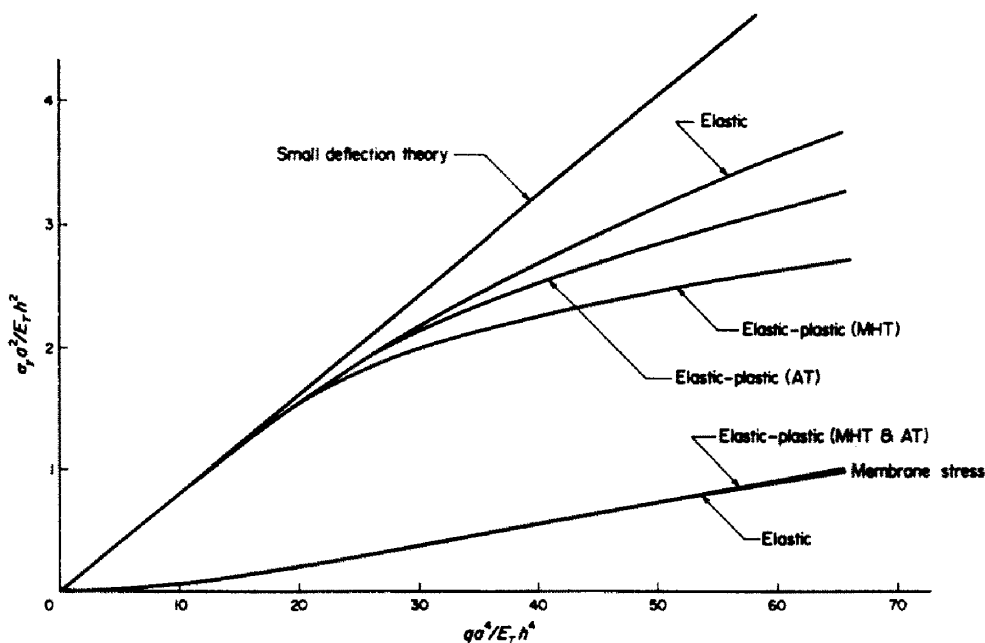

Fig. 5. Variation of the extreme fiber stress σ_y with load at the center of the plate, boron epoxy.

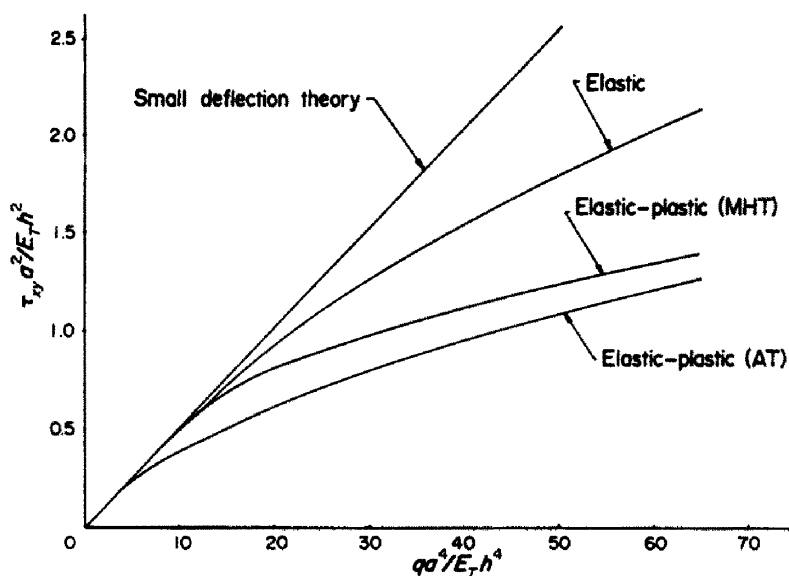

Fig. 6. Variation of the extreme fiber shearing stress with load at the corner of the plate, boron epoxy.

in the value of shearing stresses indicates the tendency of unidirectional composites to locally yield in shear at a very low stress level. Moreover, this low yielding is not clearly evident in the unidirectional test data. The phenomenon is consistent with the recent investigations of the inelastic behavior of composite materials by Adams[39] and Foye[40]. Based on the foregoing discussion, it is now obvious that the corner of the plate at the extreme surface which is under a state of pure shear yields initially.

The alternate plastic constitutive relations was also used in the analysis of a symmetrical cross-ply laminated plate of boron filament and 6061 aluminum alloy matrix. The results for this case is not presented here. However, the interpretation of the results for boron aluminum plate is similar to the previous example problem.

In the case of isotropic plates, for a lateral deflection of the order $0.4 h$, the stretching of the

middle surface can be neglected without a substantial error in the magnitude of maximum stresses and deflections[37]. However, the examination of Figs. 3–5 indicates that in the analysis of the laminated composite plates, for the lateral deflection of the order of $0.4h$, the error in the maximum deflection and stress as given by the small deflection theory becomes considerable and the strain of the middle surface must be considered.

The procedure used in this paper may be employed to solve variety of laminated plate problems under arbitrary loading, boundary conditions and stacking geometry. Furthermore, the present method can easily be extended to include the effect of temperature change in addition to external loads. The initial yield surfaces of composite laminates under arbitrary combinations of macrostresses and temperature changes can be constructed by means of a finite element analysis similar to that used by Lin *et al.*[29]. Moreover, the procedure may be extended to obtain approximate solutions for creep problems.

CONCLUSION

The solutions of the fiber-reinforced composite plate problems considered in the investigation indicate that the lateral deflection for the elastic–plastic case was slightly higher than that of a purely elastic problem for both (*MHT*) and (*AT*). The comparison of the maximum fiber stresses for elastic and elastic–plastic plates obtained from (*MHT*) and (*AT*) revealed a slight difference in the magnitude of stresses in the longitudinal direction in contrast to a more pronounced deviation of transverse stresses. It must be noted that the extreme fiber shear stress at the corner of the plate was considerably relieved by plastic strain. It was also shown that the results of (*MHT*) and (*AT*) differed markedly at the corner of the plate. Thus, the progress of the plastic zone for (*AT*) is considerably different than (*MHT*) for example problems considered. In light of the above findings, (*MHT*) does not seem to predict the real behavior of the composite materials. The comparison of the results of linear and nonlinear elastic solutions indicates that the extent of w/h within which the small deflection theory may be used for composite laminates depends upon lamina anisotropy as well as lamination geometry.

REFERENCES

1. S. G. Lekhnitskii, *Anisotropic Plates*. Gordon and Breach, New York (1968).
2. E. Reissner and Y. Stavsky, Bending and stretching of certain types of heterogeneous anisotropic elastic plates. *J. Appl. Mech.* 28(3), 402–408 (1961).
3. J. M. Whitney and A. W. Lesissa, Analysis of heterogeneous plates. *J. Appl. Mech.* 36(2), 261–266 (1969).
4. S. Yusuf, Large deflection theory of orthotropic rectangular plates subjected to edge compression. *J. Appl. Mech.* 19(4), 446–450 (1952).
5. T. Iwinski and J. Nowinski, The problem of large deflection of orthotropic plates (I). *Arch. Mech. Stosowanej* 9(5), 593–603 (1957).
6. W. A. Nash and J. R. Modeer, Certain approximate analyses of the non-linear behavior of plates and shallow shells. *Proc. Symp. Theory of Thin Elastic Shells*, 331–354, Delft (1959).
7. A. K. Basu and J. C. Chapman, Large deflexion behaviour of transversely loaded rectangular orthotropic plates. *Proc. Inst. Civil Engs* 35(1), 79–110 (1966).
8. B. Alami and J. C. Chapman, Large deflexion behaviour of rectangular orthotropic plates under transverse and in-plane loads. *Proc. Inst. Civil Engs* 43(3), 347–382 (1969).
9. C. Y. Chia, Large deflection of rectangular orthotropic plates. *J. Eng. Mech. Div. Proc. ASCE* 98(5), 1285–1298 (1972).
10. Y. C. Pao, Simple bending analysis of laminated plates by large deflection theory. *J. Comp. Mats* 4(4), 380–389 (1970).
11. G. D. Addotte, Second-order theory in orthotropic plates. *J. Structural Div. Proc. ASCE* 93(5), 343–362 (1967).
12. S. A. Zaghoul and J. B. Kennedy, The nonlinear behaviour of symmetrically laminated plates. *J. Appl. Mech.* 42(1), 234–236 (1975).
13. S. A. Zaghoul and J. B. Kennedy, The nonlinear analysis of non-symmetrically laminated plates. *J. Eng. Mech. Proc. ASCE* 101(3), 169–185 (1975).
14. R. Hill, A theory of yielding and plastic flow of anisotropic metals. *Proc. R. Soc. London*, A193(1033), 281–297 (1948).
15. R. Hill, A theory of plane plastic strain for anisotropic metals. *Proc. R. Soc. London*, A198(1054), 428–437 (1949).
16. R. Hill, *Mathematical Theory of Plasticity*. Oxford University Press, London (1950).
17. L. W. Hu, Modified tresca yield condition and associated flow rules for anisotropic materials and applications. *J. Franklin Inst.* 265(2), 187–204 (1958).
18. S. T. Wasti, The plastic bending of transversely anisotropic circular plates. *Int. J. Mech. Sci.* 12(1), 109–112 (1970).
19. E. Z. Stowell and T. S. Liu, On the mechanical behaviour of fibre reinforced crystalline materials. *J. Mech. Phys. Solids* 9(4), 242–260 (1961).
20. A. Kelly and G. J. Davies, The principles of the fibre reinforcement of metals. *Metallurgical Reviews* 10(37), 1–77 (1965).
21. D. Cratchley, Experimental aspects of fibre-reinforced metals. *Metallurgical Reviews* 10(37), 79–144 (1965).
22. P. W. Jackson and D. Cratchley, The effects of fibre orientation on the tensile strength of fibre-reinforced metals. *J. Mech. Phys. Solids* 14(1), 49–64 (1966).

23. J. F. Mulhern, T. G. Rogers and A. J. M. Spencer, A continuum model for fibre-reinforced plastic materials. *Proc. R. Soc. London*, A301(1467), 473-492 (1967).
24. W. Prager, Plastic failure of fibre-reinforced materials. *J. Appl. Mech.* 36(4), 542-544 (1969).
25. J. D. Helfinstine and R. H. Lance, Yielding of fibre-reinforced tresca materials. *J. Eng. Mech. Div. Proc. ASCE* 98(4), 849-965 (1972).
26. T. W. Butler and E. J. Sullivan, Jr., On the transverse strength of fibre-reinforced materials. *J. Appl. Mech.* 40(2), 523-526 (1973).
27. J. F. Mulhern, T. G. Rogers and A. J. M. Spencer, A continuum theory of plastic-elastic fibre-reinforced material. *Int. J. Eng. Sci.* 7(2), 129-152 (1969).
28. R. H. Lance and P. N. Robinson, A maximum shear stress theory of plastic failure of fibre-reinforced materials. *J. Mech. Phys. Solids* 19(2), 49-60 (1971).
29. T. H. Lin, D. Salinas and Y. M. Ito, Effects of hydrostatic stress on the yielding of cold rolled metals and fiber-reinforced composites. *J. Comp. Mats* 6(3), 409-413 (1972).
30. T. H. Lin, D. Salinas and Y. M. Ito, Initial yield surface of a unidirectionally reinforced composite. *J. Appl. Mech.* 39(2), 321-326 (1972).
31. L. W. Hu, Studies on plastic flow of anisotropic metals. *J. Appl. Mech.* 23(3), 444-450 (1956).
32. W. R. Jensen, W. E. Falby and N. Prince, Matrix Methods for Anisotropic Inelastic Structures. Air Force Dynamics Laboratory Report AFFDL-TR-62-200, Wright-Patterson Air Force Base, Ohio (1966).
33. T. H. Lin, *Theory of Inelastic Structures*. Wiley, New York (1968).
34. T. H. Lin, Reciprocal theorem for displacements in inelastic bodies. *J. Comp. Mats* 1(2), 144-151 (1967).
35. A. Mendelson, *Plasticity: Theory and Application*. MacMillan, New York (1968).
36. W. A. Ericson, An investigation of initial yield surfaces for unidirectional reinforced composites. Thesis for the Degree of Mechanical Engineer, Naval Postgraduate School, Monterey, California (1972).
37. S. P. Timoshenko and S. Woinowsky-Krieger, *Theory of Plates and Shells*. McGraw-Hill, New York (1959).
38. O. C. Zienkiewicz, *The Finite Element Method in Engineering Science*. McGraw-Hill, London (1971).
39. D. F. Adams, Inelastic Analysis of a Unidirectional Composite Subjected to Transverse Loading. Rand Corporation Memorandum RM-6245-PR, Santa Monica, California (1970).
40. L. Foye, Theoretical post-yielding behavior of composite laminates, Part I—Inelastic Micromechanics. *J. Comp. Mats* 7(2), 178-193 (1973).
41. Wright-Patterson Air Force Base, Advanced Composite Design Guide, 3rd Edn. Vol IV, Ohio (1973).